



TAC Xenta[®] 300

Programmable Controller

11 Aug 2003

TAC Xenta[®] 300 belongs to a family of programmable controllers designed for small and medium-sized heating and air handling systems.

A TAC Xenta 300 controller holds full HVAC functionality including control loops, curves, time control, alarm handling, etc.

Two different I/O configurations are available in the TAC Xenta 300 series controllers, which includes the TAC Xenta 301 and TAC Xenta 302. If required, separate I/O modules may be added. Both the controllers and I/O modules are designed for cabinet mounting.

The TAC Xenta 300 controller is simple to program using the graphical application programming software, TAC Menta[®].

The controller communicates on a LON^{TALK}[®] TP/FT-10 network via a twisted-pair, unpolarized cable. It is able to operate as a stand-alone unit, but can also easily be connected to a large LONWORKS based network.



TAC Xenta 300 can also be connected to a TAC Vista System[®].

For local use, the TAC Xenta OP (Operator Panel) can be connected to a TAC Xenta 300. The OP has an LCD display and push buttons for navigating and altering settings.

The OP can be connected to the network via the modular jack on the front of the programmable controllers or by attaching it to the TP/FT-10. The OP can be mounted or it can be used as a portable terminal.

TECHNICAL DATA

Supply Voltage 24 V AC $\pm 20\%$, 50/60 Hz
 or 19–40 V DC

Power Consumption max. 5 W

Transformer Sizing 10 VA

Ambient Temperature (*except* TAC Xenta 301XT/N/P):
 Storage -20 to +50 °C (-5 to +122 °F)
 Operation 0 to +50 °C (+32 to +122 °F)

Ambient Temperature TAC Xenta 301XT/N/P:
 Storage and Operation -20 to +70 °C (-5 to +158 °F)

Humidity max. 90% RH non-condensing

Mechanical:
 Enclosure ABS/PC
 Enclosure rating IP 20
 Dimensions, mm (in.) 180 x 110 x 75 (7.1 x 4.3 x 3.0)
 Weight 1,0 kg (2.2 lbs)

Real Time Clock:
 Accuracy at 25 °C (77 °F) ± 12 minutes per year
 Power failure protection 72 h

Digital Inputs (X1–X4):
 Quantity 4
 Voltage across open contact 33 V DC
 Current through closed contact 4 mA
 Pulse input duration min. 20 ms

Universal Inputs (U1–U4):
 Quantity 4
 – as Digital Inputs;
 Voltage across open contact 26 V DC
 Current through closed contact 4 mA
 Pulse input duration min. 20 ms
 – as Thermistor Inputs;
 TAC thermistor sensor 1800 ohm at 25 °C (77 °F)
 Measuring range -50 to +150 °C (-58 to +302 °F)
 – as Voltage Inputs;
 Input signal 0–10 V DC
 Input resistance 100 kohm
 accuracy within 1% of full scale

Sensor Inputs (B1–B4):
 Quantity 4
 TAC thermistor sensor 1800 ohm at 25 °C (77 °F)
 Measuring range -50 to +150 °C (-58 to +302 °F)

Digital Outputs (relays; K1–K6 or K1–K4):
 Quantity, TAC Xenta 301 6
 Quantity, TAC Xenta 302 4
 Control voltage, relay outputs up to 230 V AC
 Control current, to be protected by max. 10 A fuse,
 max. 2 A

Analog Outputs (Y1–Y2 or Y1–Y4):
 Quantity, TAC Xenta 301 2
 Quantity, TAC Xenta 302 4
 Control voltage 0–10 V DC
 Control current, short-circuit proof max. 2 mA
 Deviation max $\pm 1\%$

Communication:
 TAC Menta; modem 9600 bps, RS232, RJ45
 TAC Vista, also for appl. program download (from v 3.1),
 TP/FT-10, screw terminal
 TAC Xenta OP TP/FT-10, modular jack

LONMARK[®] Standard:
 Interoperability LONMARK Interop. Guidelines v 3.0
 Application .. LONMARK Functional Profile: Plant Controller

Agency Compliances:
 Emission C-Tick, EN 50081-1, FCC Part 15
 Immunity EN 50082-1

Safety:
 CE EN 61010-1
 UL 916 Energy Management Equipment
 ETL listing UL 3111-1, first edition
 CAN/CSA C22.2 No. 1010.1-92

Flammability class, materials UL 94 V-0

Part Numbers:
 Electronics part TAC Xenta 301/N/P 0-073-0009
 Electronics part TAC Xenta 301XT/N/P 0-073-0010
 Electronics part TAC Xenta 302/N/P 0-073-0011
 Terminal part TAC Xenta 280/300 0-073-0901
 I/O units TAC Xenta . please refer to separate data sheet
 Operator terminal TAC Xenta OP 0-073-0907
 TAC Xenta: Programming Serial Kit 0-073-0920



DESIGN

The TAC Xenta 300 controller has been designed as a general purpose unitary (one-to-one) controller. Thus, it can be mounted in close proximity to the controlled equipment, minimizing the wiring required. The TAC Xenta 300 is microprocessor based. It consists of a terminal and electronics mounted together (figure 1). The Xenta 300 can be interfaced with a wide variety of field sensors/transducers and controlled devices. All terminations of field wires are made to the terminal part only. Thus, the electronic part may be removed for service without affecting the terminal connections.

Local Operator Terminal

The TAC Xenta OP is a small operator terminal which can be connected to the unit through its enclosure. The operator can read point status, perform manual override, read measured values, alter set points etc., from the TAC Xenta OP.

The functions are selected from menus. Access to the unit is enabled by an access code. It is possible to access other TAC Xenta units on the same network.

Power Failure Protection

With non-volatile (flash) memory, the unit will start up with user defined settings and return to normal functioning after a power failure.

Real-time Clock

The clock provides data such as year, month, date, day, hour, minute and second.

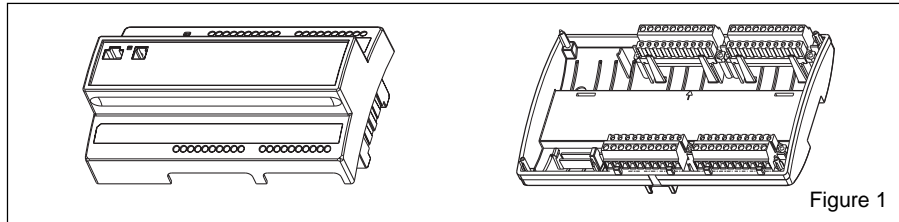

Figure 1

A built-in capacitor maintains operation of the clock for at least 72 hours in the event of a power failure.

Day-light Saving Time, European or for USA / Canada

Once set, Daylight Saving Time (DST) is fully automatic. The date of the time change, as well as the magnitude of time change can be programmed. This function can also be disabled.

Digital Inputs

The DI's are used to sense alarm contacts, status indications, pulse counting, etc. Each digital input can be used as a pulse counter (e.g. for flow measurement). Another application available when using the TAC Xenta 300 DI is for alarm monitoring. Each time an alarm is tripped, the corresponding counter can be incremented, providing data for operating statistics. The DI circuits are internally powered.

Universal Inputs

The Universal Inputs can be individually configured as Analog or Digital inputs.

A high and a low limit can be set for each Universal Input. If configured as Digital Inputs, the Universal Inputs may be used, for example, for sensing switch positions.

The Universal Input types are selected via the application program.

Digital Outputs

There are Digital Outputs for the control of equipment such as fans, pumps or similar devices. The output signal can be pulse width modulated and can be used to control increase/ decrease actuators.

Analog Outputs

There are Analog Outputs available to control actuators or the connection to controllers. No external power supply is required.

LONWORKS® SNVT Support

The use of Standard Network Variable Types according to Echelon® specification makes it possible to communicate with network nodes from other manufacturers.

I/O MODULES

TAC Xenta 300 can use up to two I/O modules from the TAC Xenta 400 series devices.

The table gives an overview of the different numbers of inputs and outputs available per module.

DI, DO: Digital Input, Digital Output

UI, TI: Universal Input, Thermistor Input

AO: Analog Output

See also the data sheets for the different modules, C-92-10, -15, -20, -25 and -30.

¹ Status indication only when the corresponding Universal Inputs (UI) are used as Digital Inputs.

² 0/4–20 mA; 0–1, 0/2–10 V DC

I/O module TAC	DI	DI status	DO	DO override	UI	TI	AO	AO override
Xenta 411	10	-	-	-	-	-	-	-
Xenta 412	10	10	-	-	-	-	-	-
Xenta 421	4	-	5	-	-	-	-	-
Xenta 422	4	4	5	5	-	-	-	-
Xenta 451	-	-	-	-	4	4	2	-
Xenta 452	-	4 ¹	-	-	4	4	2	2
Xenta 471	-	-	-	-	8 ²	-	-	-
Xenta 491	-	-	-	-	-	-	8	-
Xenta 492	-	-	-	-	-	-	8	8
Xenta 301	4	-	6	-	4	4	2	-
Xenta 302	4	-	4	-	4	4	4	-

SOFTWARE FEATURES

With the assistance of TAC Menta, a graphical programming tool using Functional Block Diagrams (FBDs), the TAC Xenta 300 may be easily adapted to different control and monitoring tasks.

The basic software includes pre-programmed routines for:

- reading of Digital Inputs (alarms, pulse counting, interlocks)
- reading of Universal Inputs (individually selectable as Analog or Digital)
- control of Digital Outputs
- control of Analog Outputs
- on and off delays

- pulse counting (Digital Inputs only)
- alarm handling; alarm conditions may be detected via the digital or the analog inputs.
- equipment run time totals, on selected objects.
- time schedules (start and stop times in hours and minutes): weekly and holidays
- optimum start/stop programs
- control characteristic curves
- PID control loops (loops may be connected in cascade)
- from v 3.2 trend logging for up to 50 channels is possible (hw version 2 required)
- connection to one or two optional I/O modules
- local level operator interface via TAC Xenta OP
- network communication according to the LONTALK® protocol
- communication with the Central System via modem

The basic software is adapted to the current application by connecting pre-programmed Functional Blocks and by adjusting the relevant parameters. These connections and parameters are stored in a non-volatile memory.

The parameters may be changed during ongoing operation either from the Central System or locally from the TAC Xenta OP (Operator Panel).

COMMUNICATION

Communication Capabilities

The TAC Xenta 300 has several communication capabilities within a Network with a central presentation system and/or a hand-held Operator Panel.

LONWORKS Connection

TAC Xenta controllers communicate with each other using a common network, LONWORKS TP/FT-10, 78 kbps. A number of controllers can form a network and exchange data.

Additional I/O units also connect to the network and may be added as required. An I/O unit can only be associated with one controller.

The LONTALK protocol makes it possible to use Network Variables defined in equipment from third party manufacturers.

The Functional Block applications are Modeled as true LONMARK® Controller Objects.

The Network Variable interface (including the Standard Network Variable Types, SNVTs) can be customized, and External Interface Files (XIFs) can be generated with the TAC Menta tool.

TAC Vista Presentation System

When connected to a TAC Vista Central System, the operating conditions of the fans, pumps, recovery units, etc. can be monitored in color graphics or printed reports. Temperatures and alarms can be read, while setpoints, time settings may be altered as required.

TAC Xenta controllers can communicate with TAC Vista in one of the following ways.

- 1 All nodes on the LAN via a PCLTA card.
- 2 A specific programmable controller via the RS232 connection, possibly via modem (all v 3.x).
- 3 Any programmable controller in the network via TAC Xenta 901 LonTalk adapter (and an optional modem connection), with the added possibility for the programmable controller to initiate the dial-up (the latter only for v 3.2).

Starting with v 3.1 controller software, application programs generated in TAC Menta may be downloaded from TAC Vista via the network.

TAC Xenta OP Port

The operator panel is also connected to the network and can thus act as an operator panel for other units in the network. The connection is made to the modular jack on the front of the controller or directly to the network cable.

RS232 Port

The TAC Xenta 300 controller has an RS232 port. This port is intended for direct connection to a PC with the TAC Menta programming tool for loading the application program.

The port can also be used for connection between TAC Vista and specific TAC Xenta 300 units (see 2 under "TAC Vista Presentation System" above).

SYSTEM CONFIGURATIONS

The TAC Xenta 300 controllers can be used in different configurations.

- Stand-alone
- Controllers and OPs in a network, with extra I/O modules as required
- Controllers, OPs, I/O modules and other equipment in a full network with suitable adapters, possibly with connection to a TAC Vista Central System (CS)

Figure 2 shows an example of TAC Xenta network configuration.

Sensors and actuators on the Field level are mostly connected to the conventional inputs/outputs of the controllers or I/O-modules.

Some external units, however, may connect directly to the network to communicate input/output data, using Standard Network Variables (SNVTs).

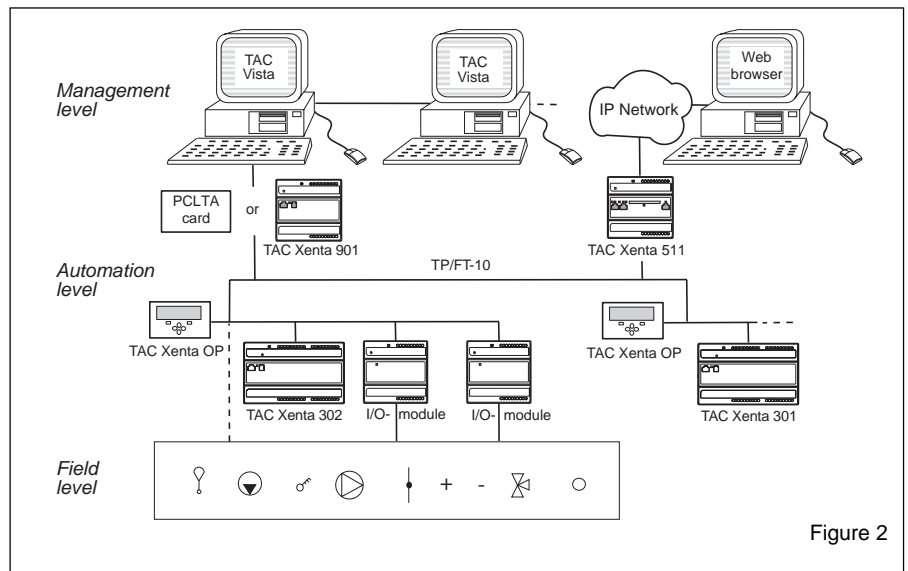

Figure 2

TAC XENTA NETWORK AND UNIT PERFORMANCE

Per TAC Vista Server

No. of programmable controllers 400
 No. of I/O modules 200
 No. of Operator Panels 100
 No. of TAC Xenta Groups 30
 No. of programmable controllers per Group 30

Per TAC Xenta Base unit:

No. of I/O modules
 TAC Xenta 301 /N/P, 302 /N/P 2

No. of subscriptions*

In max. 15
 Out max. 30

Trend logging in TAC Xenta 300 (from v 3.3, hw version 2)

Channels 1 – 50
 Interval 10 s – 530 weeks
 Total logging cap. ~ 4000 float. no.s
 or ~ 8000 integers
 or ~ 60 000 digital values
 Optimized storage Yes

Application size

program and data max. 56 kB
 parameters max. 64 kB

* Subscriptions may utilize SNVTs or TACNVs (TAC Network Variables). These may be combined if the following restrictions are observed: The sum of the TACNV subscriptions and the number of SNVT members (no. of values in structured SNVTs) must not exceed the stated figures.

MOUNTING

The TAC Xenta 300 controller is cabinet mounted on a TS 35 mm Norm rail EN 50 022.

The controller consists of two parts; a terminal with the screw terminals, and the electronics with the circuit boards. To simplify installation, the terminal can be pre-mounted (see figure 1).

If the Xenta 300 controller is to be wall mounted, a wide range of standardized boxes are available.

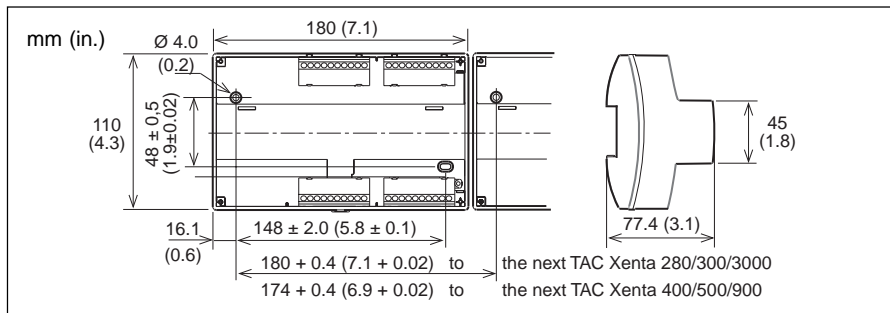

CABLES

G and G0:

Min. cross-sectional area 0.75 and 1.5 mm² (19 and 16 AWG).

Cable with modular jack for RS232 serial communication port: Max. 10 m (32 ft).

Terminals X1–X4:

Min. wire size 0,25 mm² (23 AWG).

Max. cable length 200 m (650 ft).

Terminals U1–U4, B1–B4, Y1–Y4:

Min. wire size of 0,25–0,75 mm² (23 to 19 AWG).

Max. cable length 20–200 m (65 to 650 ft) (see TAC Xenta 280/300/401 manual for details).

Terminals K1–K6:

Wire size 0,75–1,5 mm² (19 to 16 AWG).

Max. cable length 200 m (650 ft).

C1 and C2:

TP/FT-10 allows the user to wire the control devices with virtually no topology restrictions. The max. wire distance in one segment depends on the type of wire and the topology (see the table below).

The TAC Xenta Network guide (0-004-7460) gives a more detailed description.

Cable	Max. bus length, doubly terminated, bus topology, m (ft)	Max. node-to-node distance, singly terminated, free topology, m (ft)	Max. length, singly terminated free, topology, m (ft)
Belden 85102, single twisted pair	2700 (9000)	500 (1600)	500 (1600)
Belden 8471, single twisted pair	2700 (9000)	400 (1300)	500 (1600)
UL Level IV 22AWG, twisted pair	1400 (4600)	400 (1300)	500 (1600)
Connect-Air 22AWG, one or two pairs	1400 (4600)	400 (1300)	500 (1600)
Siemens J-Y(st)Y 2x2x0.8	900 (3000)	320 (1000)	500 (1600)
4-wire helical twist, solid, shielded			
TIA568A Cat. 5 24AWG, twisted pair	900 (3000)	250 (820)	450 (1500)

INSTALLATION

The two TAC Xenta 300 controllers have different outputs. The adjacent table shows the terminal connections of the two TAC Xenta controllers.

There is a label on the front of the controller with both the numbers and the names of the terminals (1 C1, 2 C2 and so on). The numbers are also shown in the plastic of the terminal part.



Note! Installation of high voltage cables must be performed by qualified personnel!

For detailed information, please refer to the TAC Xenta 280/300/401 Handbook (part no. 0-004-7768).

Operator Panel

The operator panel is easily connected to the network by means of the modular socket on the front of the controller.

LED Indicator

An indicator on the electronic unit of the TAC Xenta 300 indicates when the application program is running.

Service Pin

To simplify network commissioning, there is a service pin on the electronic unit which, when pressed, identifies the unit on the network.

Terminal Connections: Inputs

Term. No.	Term.name	Description
	301/302	
1	C1	} LONWORKS
2	C2	
3	U1	Universal
4	M	Measurement. neutral
5	U2	Universal
6	U3	Universal
7	M	Measurement. neutral
8	U4	Universal
9	B1	Thermistor
10	M	Measurement. neutral
11	B2	Thermistor
12	B3	Thermistor
13	M	Measurement. neutral
14	B4	Thermistor
15	X1	Digital
16	M	Measurement. neutral
17	X2	Digital
18	X3	Digital
19	M	Measurement. neutral
20	X4	Digital

Terminal Connections: Outputs

Term. No.	Term.name	Description
	301 302	
21	G G	24 V AC (or DC+)
22	G0 G0	24 V AC common
23	Y1 Y1	0–10 V
24	M M	Output neutral
25	Y2 Y2	0–10 V
26	– Y3	0–10 V
27	– M	Output neutral
28	– Y4	0–10 V
29	– –	
30	– –	
31	K5 –	Relay
32	KC3 –	K5, K6 common
33	K6 –	Relay
34	K1 K1	Relay
35	KC1 KC1	K1, K2 common
36	K2 K2	Relay
37	K3 K3	Relay
38	KC2 KC2	K3, K4 common
39	K4 K4	Relay
40	– –	

MAINTENANCE

Caring for the controller includes keeping it dry and cleaning it externally with a dry cloth when needed.

TAC and TAC products are trademarks and/or registered trademarks of TAC AB.

All other trademarks belong to their respective owners. Copyright 2003 © TAC AB. All rights reserved.

www.tac.com