

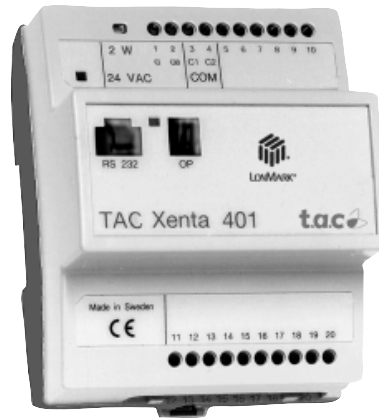

TAC Xenta[®] 401

Controller, Freely programmable

29 Aug 2002



TAC Xenta[®] 401 belongs to a family of freely programmable controllers, with communication features, designed for heating and air handling systems.

A TAC Xenta 401 holds full HVAC functionality including control loops, curves, time control, alarm handling etc. The controller does not have any inputs or outputs. Instead, required I/O modules from the TAC Xenta 400 series are used.

Up to 10 I/O modules can be connected to the TAC Xenta 401. The controller is designed for cabinet mounting.

With TAC Menta[®] graphical tool, a TAC Xenta controller is simple to program and place into operation.

The controller communicates on a LONTALK[®] TP/FT-10 network via a twisted-pair, unpolarized cable. It is able to operate both as a stand-alone unit and as part of a system.

TAC Xenta 401 can be connected to a modem or the TAC Vista[®] central system.

For local use the TAC Xenta OP operator panel can be connected to TAC Xenta. It has a display with backlight and a minimum number of push buttons to take readings and alter settings.

The operator panel can be mounted in the cabinet front or be used as a portable terminal.

TECHNICAL DATA

Supply voltage 24 V AC $\pm 20\%$, 50/60 Hz
or 19–40 V DC

Power consumption max. 2 W
Transformer sizing max. 2 VA

Ambient temperature:

Storage -20 to 50 °C (-4 to 122°F)
Operation 0 to 50 °C (+32 to 122°F)
Humidity max. 90% RH non-condensing

Mechanical:

Enclosure ABS/PC
Enclosure rating IP 20
Dimensions see diagram
Weight 0.5 kg (1.2 lbs)

Real time clock:

Accuracy at +25 °C ± 12 minutes per year
Power failure protection 72 h

Communication:

TAC Menta; modem 9600 bps, RS232, RJ45
TAC Vista, also for appl. pgm download (from v 3.1),
..... TP/FT-10, screw terminal
TAC Xenta OP TP/FT-10, modular jack

LONMARK[®] standard:

Interoperability LONMARK Interop. Guidelines v 3.0
Application .. LONMARK Functional Profile: Plant Controller

mm (in.):

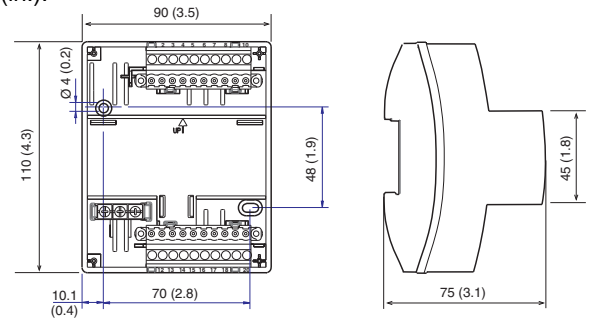

Agency Compliances:

Emission C-Tick, EN 50081-1, FCC Part 15
Immunity EN 50082-1

Safety:

CE EN 61010-1
UL 916 Energy Management Equipment
ETL listing UL 3111-1, first edition
..... CAN/CSA C22.2 No. 1010.1-92
Flammability class, materials UL 94 V-0

Part number:

Electronics part TAC Xenta 401 0-073-0101
Terminal part TAC Xenta 400 0-073-0902
Operator terminal TAC Xenta OP 0-073-0907
TAC Xenta: Programming Serial Kit 0-073-0920



DESIGN

The TAC Xenta 401 controller has been designed as a general purpose controller. It is normally mounted in a cabinet, with several controllers collected per floor or per building. Its I/O modules can be mounted in close proximity to the controlled equipment, thereby minimizing the wiring required.

TAC Xenta 401 is microprocessor based. It consists of a terminal and electronics mounted together (figure 1). TAC Xenta 401 can, via its I/O modules, be interfaced with a wide variety of field sensors/transducers and controlled devices.

Local operator terminal

The TAC Xenta OP is a small operator terminal which can be connected to the unit through a jack on the front. The operator can read point status, perform manual override, read measured values, alter set points, etc. from the Xenta OP.

The functions are selected from menus. Access is enabled by a code. It is also possible to access the other TAC Xenta units on the same network.

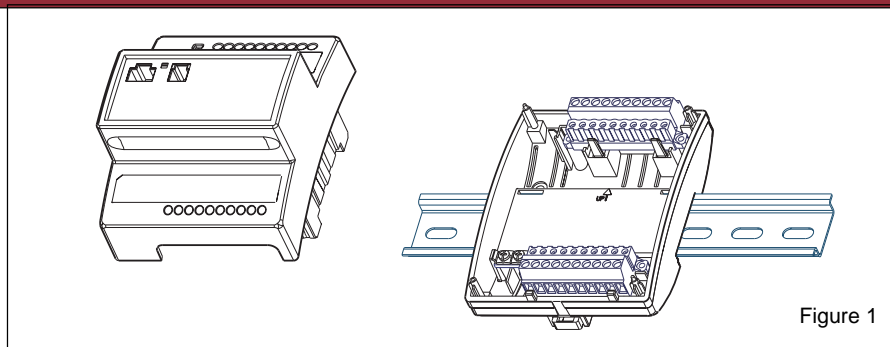

Figure 1

Power failure protection

With non-volatile (flash) memory, the unit will start up with user settings and work normally after a power failure.

Real-time clock

The real-time clock provides data such as year, month, date, day, hour, minute and second. A built-in capacitor maintains operation of the clock for at least 72 hours in the event of a power failure.

Daylight Savings Time

European or USA / Canada

Once set, Daylight Savings Time (DST) is fully automatic. The date of the time change, as well as the magnitude of time change can be programmed. This function can also be disabled.

LONWORKS® SNVT support

The use of Standard Network Variable Types according to Echelon® specification makes it possible to communicate with nodes from other manufacturers.

I/O MODULES

TAC Xenta 401 has no inputs or outputs by itself. Instead, the required number of I/O modules from the TAC Xenta 400 series are used.

The TAC Xenta 401 can have up to 10 I/O modules.

The table gives an overview of the different numbers of inputs and outputs.

DI, DO: Digital input, output
 UI: Universal input
 TI: Thermistor input
 AO: Analog output

I/O module TAC	DI	DI status	DO	DO override	UI	TI	AO	AO override
Xenta 411	10	-	-	-	-	-	-	-
Xenta 412	10	10	-	-	-	-	-	-
Xenta 421	4	-	5	-	-	-	-	-
Xenta 422	4	4	5	5	-	-	-	-
Xenta 451	-	-	-	-	4	4	2	-
Xenta 452	-	4 ¹	-	-	4	4	2	2
Xenta 471	-	-	-	-	8 ²	-	-	-
Xenta 491	-	-	-	-	-	-	8	-
Xenta 492	-	-	-	-	-	-	8	8

¹ Status indication only when the corresponding universal inputs (UI) are used as digital inputs.

² 0/4–20 mA; 0–1, 0/2–10 V DC

SOFTWARE FEATURES

With the assistance of TAC Menta, a graphical programming tool using Functional Block Diagrams (FBDs), the TAC Xenta 401 may be easily adapted to different control and monitoring tasks.

The basic software includes pre-programmed routines for:

- reading of Digital Inputs (alarms, pulse counting, interlocks)
- reading of Universal Inputs (individually selectable as analog or digital)
- control of Digital Outputs
- control of Analog Outputs
- alarm handling; alarm conditions may be detected via the digital or the analog inputs.

- on/off delays
- pulse counting (Digital Inputs only)
- equipment run time totals on selected objects.
- time schedules (start and stop times in hours and minutes): weekly and holidays
- optimum start/stop programs
- control characteristic curves
- PID control loops (loops may be connected in cascade)
- from v 3.2 trend logging for up to 50 channels is possible
- connection to 10 I/O modules
- local level operator interface via TAC OP

- network communication according to the LONTALK® protocol
- communication with Central System via modem

The basic software is adapted to the current application by connecting pre-programmed function blocks and adjusting the relevant parameters. These connections and parameters are stored in non-volatile memory.

The parameters may be changed during ongoing operation either from the Central System or from the TAC OP operator panel.

COMMUNICATION

LONWORKS connection

TAC Xenta controllers communicate with each other using a common network, LONWORKS TP/FT-10.78 kbps.

Associated I/O modules also connect to the network. An I/O modules can only be associated with one controller.

When connected to a TAC Vista Central System, the operating conditions of the fans, pumps, recovery units etc. can be monitored in color graphics or printed reports.

Temperatures and alarms may be read, while setpoints, time settings may be altered as required.

TAC Xenta base units can be reached from TAC Vista in one of the following ways:

- 1 Any base unit in the network via a PCLTA card.
- 2 A specific base unit via the RS232 connection, possibly via modem (all v 3.x).
- 3 Any base unit in the network via TAC Xenta 901 LonTalk adapter (and an optional modem connection), with the added possibility for the base unit to initiate the dial-up (the latter only for v 3.2).

Starting with v 3.1, application programs generated in TAC Menta may be downloaded from TAC Vista via the network.

TAC OP port

The operator panel is also connected to the network and can thus act as an operator panel for other units in the network. The connection is made to the modular jack on the front of the controller, or directly to the net cable.

RS232 port

The TAC Xenta 401 controller has an RS232 port. This port is intended for connection to a PC with the TAC Menta programming tool for loading and commissioning the application programs.

The port can also be used for connection via modem between TAC Vista and specific TAC Xenta 401 units (see above).

SYSTEM CONFIGURATIONS

The TAC Xenta base units can be used in different configurations.

- Stand-alone (together with the required I/O modules).
- Controllers, I/O modules and OPs in small networks.
- Controllers, OPs, I/O modules and other equipment in full network with suitable adaptors, possibly with connection to a TAC Vista Central System (CS)

Figure 2 shows an example of a networked TAC Xenta configuration.

Sensors and actuators on the Field level are mostly connected to the conventional inputs and outputs of the I/O-modules.

Some external units, however, may connect directly to the network to communicate input/output data, using Standard Network Variables.

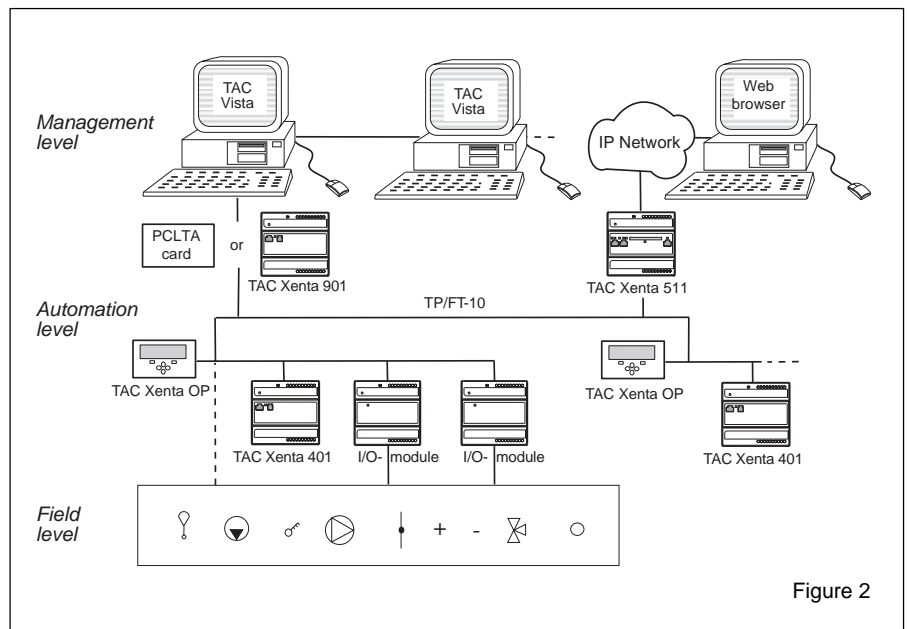

Figure 2

TAC XENTA NETWORK AND UNIT PERFORMANCE

No. of Base units	400
No. of I/O modules	200
No. of Operator Panels	100
No. of TAC Xenta Groups	30
No. of Base units per Group	30
Per TAC Xenta 401 unit:	
No. of I/O modules	10
No. of subscriptions *	
In	max. 125
Out	max. 125

Trend logging in TAC Xenta 401, from v 3.3	
Channels	1 – 50
Interval	10 s – 530 weeks
Total logging cap. ~ 7000 float. no.s	or ~ 15,000 integers
Optimized storage	Yes
Application size	
From v 3.2	
program and data	max. ~234 kB
parameters	max. ~234 kB
Up to v 3.1	
program and data	max. 57 kB
parameters	max. 64 kB

* Subscriptions may utilize standard SNVTs or TACNVs (TAC Network Variables). These may be combined if the following restrictions are observed: The sum of the TACNV subscriptions and the number of SNVT members (no. of values in structured SNVTs) must not exceed the stated figures.

MOUNTING

The TAC Xenta 401 is cabinet mounted on a TS 35 mm Norm rail EN 50 022. The controller unit consists of two parts; a terminal part with screw terminals, and electronics with the circuit boards.

To simplify installation, the terminal can be pre-mounted in the cabinet (see figure 1).

The operator panel is either mounted onto the controller on the snap-in connector, or flush-mounted in the cabinet front. It can also be used as a portable, hand held panel.

If the TAC Xenta 401 controller is wall mounted, a wide range of standardized boxes are available.

CABLES

G and G0:

Min. cross-sectional area 0,75 and 1,5 mm² (19 and 16 AWG).

Cable with modular jack for RS232 serial communication port: Max. 10 m (32 ft).

C1 and C2:

TP/FT-10 allows the user to wire the control devices with virtually no topology restrictions. The max. wire distance in one segment depends on the type of wire and the topology, see the table below.

The TAC Xenta Network guide (part no. 0-004-7460) gives a more detailed description.

Cable	Max. bus length, doubly terminated bus topology m (ft)	Max. node-to-node distance, singly terminated free topology m (ft)	Max. length, singly terminated free topology m (ft)
Belden 85102, single twisted pair	2700 (9000)	500 (1600)	500 (1600)
Belden 8471, single twisted pair	2700 (9000)	400 (1300)	500 (1600)
UL Level IV 22AWG, twisted pair	1400 (4600)	400 (1300)	500 (1600)
Connect-Air 22AWG, one or two pairs	1400 (4600)	400 (1300)	500 (1600)
Siemens J-Y(st)Y 2x2x0.8 4-wire helical twist, solid, shielded	900 (3000)	320 (1000)	500 (1600)
TIA568A Cat. 5 24AWG, twisted pair	900 (3000)	250 (820)	450 (1500)

INSTALLATION

There is a label on the front of the controller with both the numbers and the names of the terminals (1 C1, 2 C2 and so on). The numbers are also shown in the plastic of the terminal part.

Operator panel

The operator panel is easily connected to the network thorough the modular socket on the front of the controller.

LED indicator

An indicator on the electronic unit of the TAC Xenta 401 indicates when the application program is running.

Service pin

To simplify network commissioning, there is a service pin on the electronic unit which, when pressed, identifies the unit on the network.

Terminal connections

Term. no.	Term. name	Description
1	G	24 V AC (or DC+)
2	G0	24 V AC common
3	C1	LONWORKS TP/FT-10
4	C2	

MAINTENANCE

The only care needed is to keep the controller dry and to clean it externally with a dry cloth when needed.