



TAC Xenta[®] 511, 2.1

Web Server for LONWORKS[®] Network

30 June 2003

The TAC Xenta 511 is a web based presentation system for LONWORKS networks. Using a standard web browser, the operator can easily view and control the devices in the LONWORKS network via Internet or a local intranet.

One TAC Xenta 511 can present a small LONWORKS network or be one of several local presentation devices in a larger network.

Explore the TAC Xenta 511 web site with the web browser, check and acknowledge alarms from the LONWORKS network or change setpoints or operating conditions. Time schedules and trend logs are also easily accessed.

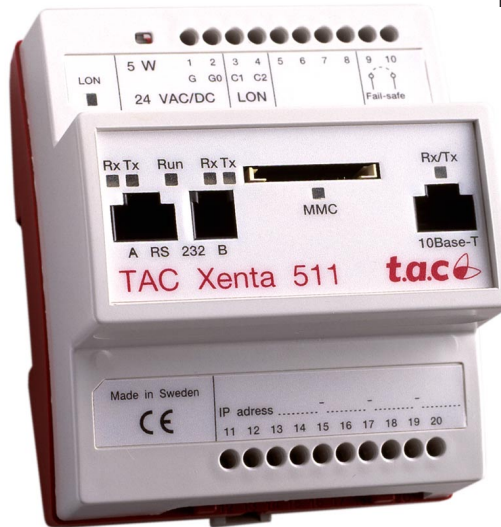

The web pages are based on standard Internet technology as HTML and Java[™] Applets.

Alarms can be forwarded as e-mail or as SMS.

The TAC Xenta 511 has a special function as an LTA, LonTalk[®] Adapter, between TAC Vista[®] and the LONWORKS network.

The TAC Xenta 511 uses the HTTPS, which is regarded as one of the most secure protocols on the Internet.

TAC Xenta 511 is equipped with an on-line help function that facilitates configuring and daily operation.

TECHNICAL DATA

Supply voltage 24 V AC $\pm 20\%$, 50/60 Hz
 or 19–40 V DC

Power consumption max. 5 W
 Transformer sizing 5 VA

Ambient temperature:
 Storage $-20\text{ }^{\circ}\text{C}$ to $+50\text{ }^{\circ}\text{C}$ ($-4\text{ }^{\circ}\text{F}$ to $+122\text{ }^{\circ}\text{F}$)
 Operation $\pm 0\text{ }^{\circ}\text{C}$ to $+50\text{ }^{\circ}\text{C}$ ($+32\text{ }^{\circ}\text{F}$ to $+122\text{ }^{\circ}\text{F}$)

Humidity max. 90% RH non-condensing

Mechanical:
 Enclosure ABS/PC
 Enclosure rating IP 20
 Dimensions see diagram
 Weight 0.2 kg (0.44 lb.)

Real time clock:
 Accuracy at $+25\text{ }^{\circ}\text{C}$ ± 14 minutes per year
 Power failure protection 72 h

Communication:
 Modem 9 600-57 600 bps RS232A, RJ45, 8-p
 PC, configuration RS232B, RJ10, 4-p
 LONWORKS TP/FT-10, terminal block
 Ethernet TCP/IP, 10Base-T, RJ45

Storage:
 Nonvolatile ... System software, applications, files ... 8 MB
 External memory, MMC Files 4-128 MB

Agency Compliances:
 Emission C-Tick, EN 50081-1, FCC Part 15
 Immunity EN 50082-1

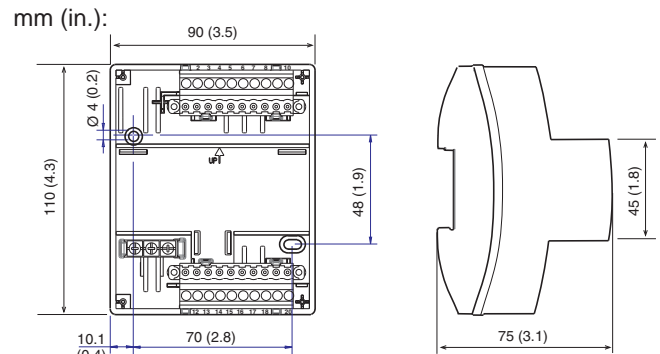

Safety:
 CE EN 61010-1
 UL 916 Energy Management Equipment
 ETL listing UL 3111-1, first edition
 CAN/CSA C22.2 No. 1010.1-92
 Flammability rating UL94V-0

Part numbers:
 Electronics part TAC Xenta 511 0-073-0811
 Terminal part TAC Xenta 400 0-073-0902
 TAC Xenta: PC to Serial Kit 0-073-0917
 TAC Xenta: Serial Link Kit 0-073-0918
 TAC Xenta: General Serial Kit 0-073-0919
 TAC Xenta: Programm. Serial Kit 0-073-0920



SYSTEM ARCHITECTURE

The web presentation of events and status from the LONWORKS network is reached through Ethernet or the RS232 port A (figure 1).

The TAC Xenta 511 is one of the nodes in the LONWORKS network. A binding tool, for example LonMaker™, can be used for installing the TAC Xenta 511 in the network. When using TAC Vista IV no binding tool is needed.

TAC Xenta 511 communicates via SNVT or TAC proprietary protocol with the rest of the LONWORKS nodes.

A modem or an Inovonics receiver can be connected to the Xenta 511 using the RS232 port A.

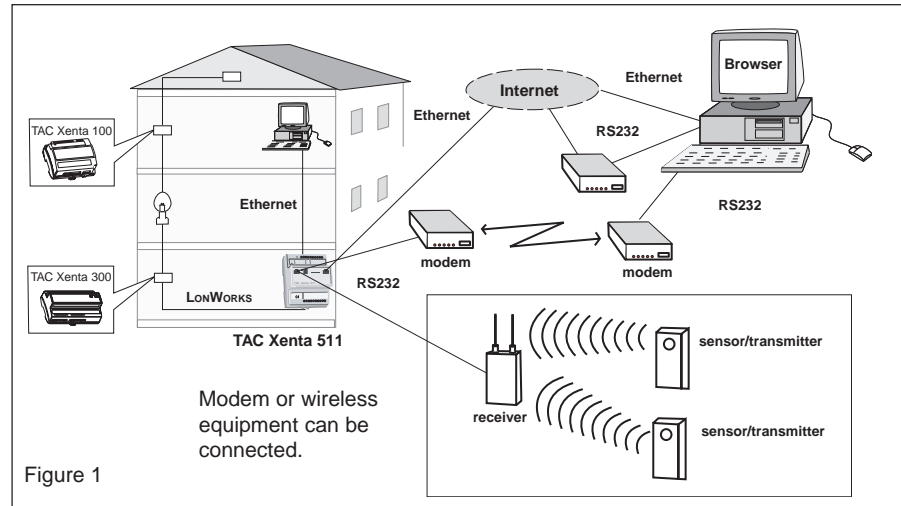

LTA for TAC Vista

The TAC Xenta 511 can be used as an LTA, LonTalk Adapter, between TAC Vista and the LonWorks network.

When using TAC Vista 3.x, the program LTA for TAC Vista is used for the configuration of the LTA function in the TAC Xenta 511.

When using TAC Vista IV the LTA support is built into TAC Vista IV.

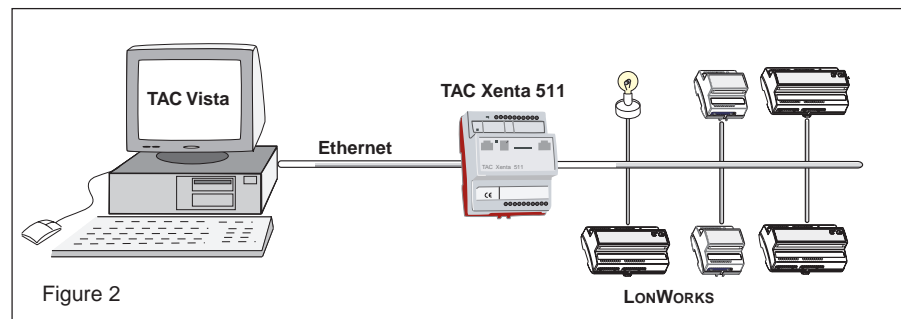

SERVER FUNCTIONS

Modem

The serial channel port A in TAC Xenta 511 supports modem signals.

TAC Xenta 511 has both dial-up and dial-in capability and alarms can be sent as e-mail or SMS.

TAC Xenta 511 (2.1) supports PAP and CHAP authentication.

File Server

An FTP (*File Transport Protocol*) server in the TAC Xenta 511 makes file transfer possible.

Web Server

The web server in the TAC Xenta 511 is used for configuration and presentation of data from the units in the LONWORKS network. The web server supports HTTP version 1.0.

Time Synchronization

The TAC Xenta 511 internal time can be synchronized with an external Time Server using NTP (Network Time Protocol) or with another TAC Xenta 511, using SNTP (Simple NTP).

Moreover, the TAC Xenta 511 can synchronize the time in local LonWorks networks with TAC Xenta 30x/4xx units.

WEB BROWSER

TAC Xenta 511 is optimized for Microsoft Internet Explorer version 6.0.

Java Applets

Support for Java Applets might not be available in all web browsers. If so, a Java plug-in must be installed, otherwise the web pages based on Java Applets can not be used.

Java Plug-ins for download are found at Sun Microsystems site for Java technology at <http://java.sun.com> or at <http://download.tac.com/software/sun/java/javadownload.html>

WIRELESS EQUIPMENT

Using the RS232 port A, an Inovonics FA7403 receiver can be connected to the network. This makes it possible to use wireless sensors/transmitters from Inovonics. 400 devices may be connected to the network.

The wireless equipment operates on the 900MHz frequency. For more information see datasheet 003-2556.

SECURITY

The TAC Xenta 511 is provided with mechanisms to guarantee a high level of security.

A large number of users may use the Xenta 511, each with his or hers individually tailored access authority.

The unit is protected against both unauthorized access and incorrect operation.

A login procedure will give the user access only to those functions he or she is authorized to see and use.

User accounts and access rights can be administered via the web interface.

The security mechanism is based on HTTPS and the use of 128 bit encryption keys. This level of security is considered to be very high and is used by many international banks and e-commerce sites.

FUNCTIONS

The web pages based on HTML in the TAC Xenta 511 are used for presentation of status, trends, graphics, and alarms. The programming tool, TAC XBuilder, is used for designing, generating and maintaining the pages.

TAC XBuilder is also used for defining and configuring the network variables used for trend logs, alarm objects and historical logging.

Status Viewer

The Status Viewer displays dynamic data such as setpoints, process values and parameters, in an easy to understand table view (figure 3). An authorized user can set values in the status viewer.

Trend Viewer

The Trend Viewer displays a graphical presentation of historical logged data (figure 4).

The log can be activated either manually or automatically with a condition and/or a starting time.

Graphics Viewer

The Graphics Viewer displays a graphical presentations of the site or the installation, used for swift and easy monitoring.

In the Graphics Viewer operating values are dynamically updated and current alarm status is shown (figure 5). An authorized user can change values and acknowledge alarms in the Graphics Viewer.

Alarm Viewer

The Alarm Viewer displays information about alarms from the alarm objects (figure 6). The operator can read, acknowledge, block and sort the alarms in the Alarm Viewer.

In the historical alarm list the type of alarm, date/time and operator are logged. New alarms are automatically registered in the historical alarm list. When the list is full the oldest alarm is overwritten.

Time Object Editor

The Time Object Editor displays configuration of time objects (figure 7). The Time Object Editor makes it possible to edit or create new schedules.

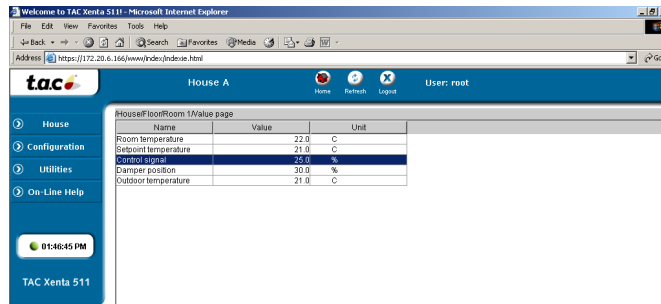

Figure 3

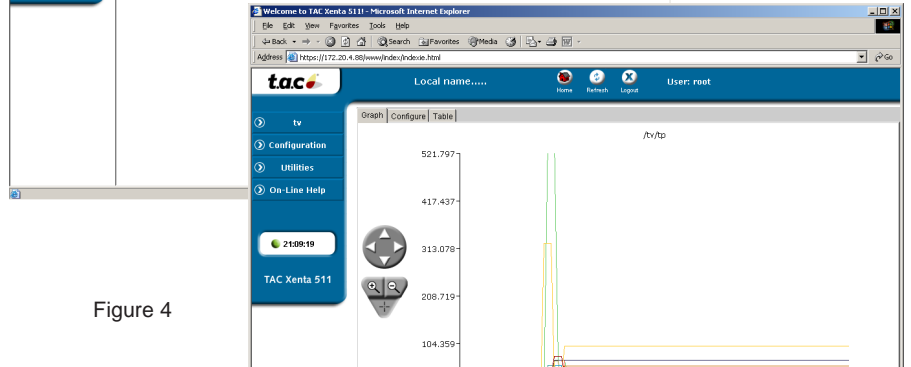

Figure 4

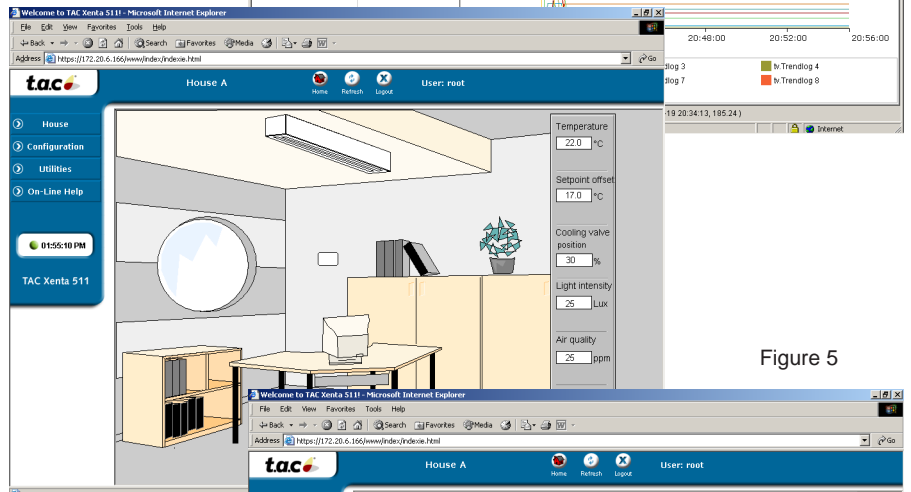

Figure 5

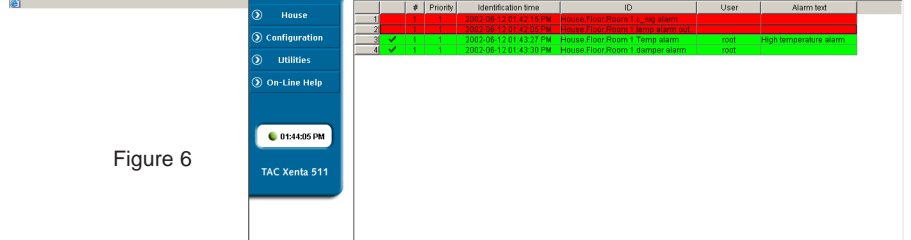

Figure 6

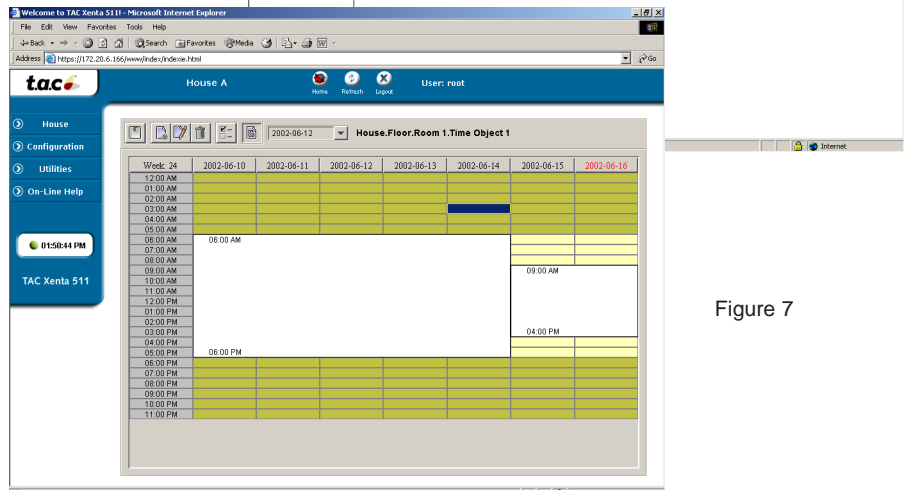

Figure 7

PERFORMANCE

LonWorks Network

The TAC Xenta 511 has the capacity to supervise a LONWORKS network with approximately 30 nodes. The amount of SNVTs possible to bind to each unit is about 400. Both polled and bound SNVTs can be monitored.

Trend Viewer

The capacity for trend logging objects is a maximum of 150 objects for each TAC Xenta 511. Up to 100 000 values can be logged.

Alarm

The TAC Xenta 511 can supervise 150 alarm objects at the same time, both from the LONWORKS network, SNVTs, and from the unit itself. The signals can be both digital and analog.

Time Schedules

The TAC Xenta 511 can handle 50 time objects with 50 week and 50 holiday schedules in each.

ACCESSORIES

Serial Communication

For installing the TAC Xenta 511, *TAC Xenta 511: Programming Serial Kit, part no. 0-073-0920* is needed, ordered separately.

Modem Connection

For connecting the TAC Xenta 511, *TAC Xenta Modem Connect kit part no. 0-073-0916* is needed, ordered separately.

Cable

The TAC Xenta 511 is connected to the local network with a standard UTP-cable or a standard STP-cable. For more information see *TAC Xenta Cable Guide 0FL-3972*.

CABLES

G and G0:

Min. cross-sectional area 0.75 mm² (AWG-19).

C1 and C2:

TAC Xenta 511 communicates on a joint network, LONWORKS[®] TP/FT-10, 78 kbps.

DESIGN AND MOUNTING

The TAC Xenta 511 is designed around a microprocessor. The device consists of two parts, a terminal including the terminal block, and the electronics with the circuit boards and contacts (figure 8).

Power Failure Protection

Settings, like configuration and web pages, are stored in the non-volatile (flash) memory and will not be lost after a power failure.

Real Time Clock

The clock provides the internal event log with a time stamp. A built-in capacitor maintains operation of the clock for at least 72 hours in the event of a power failure.

Mounting

The TAC Xenta 511 is cabinet mounted on a TS 35 mm norm rail EN 50022.

To simplify installation, the terminal can be pre-mounted in the cabinet, (figure 8).

If the TAC Xenta 511 is to be wall mounted, a wide range of standardized boxes are available.

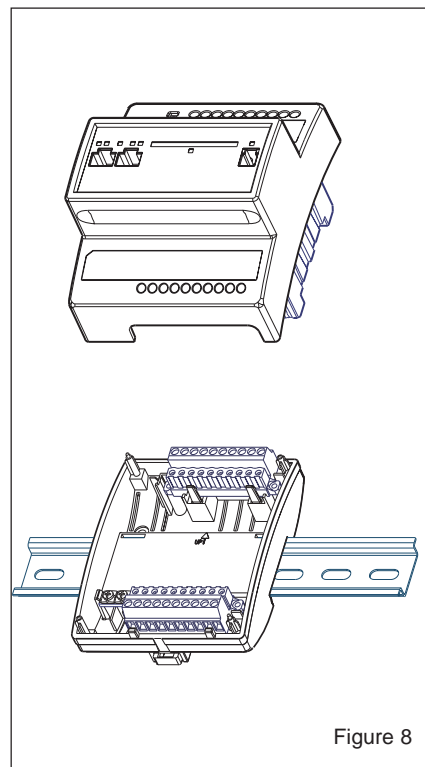

Figure 8

INSTALLATION / CONNECTIONS

Modular Jacks

RS232 port A: Modem connection

Connection using hardware signals for modem communication, either as a DTE or a DCE.

RS232 port B: PC ('Console') connection

Connection using basic signals, primarily intended for a PC at configuration and commissioning.

10Base-T

Connection for a LAN (Ethernet) cable.

MMC

Connection for a MultiMedia Card.

LEDs

A number of light-emitting diodes on the electronics part of the TAC Xenta 511 modem indicates that the application program is running and when communication is in progress.

"Reset Button"

Shorting the terminals 9 and 10 ("Fail-safe 1 and 2") will terminate any program hang-up and bring the internal program to a fail-safe state.

Terminal Connections

There is a label on the front of the device with both the numbers and the names of the terminals (1 G, 2 G0 and so on). The numbers are also shown in the plastic of the terminal.

Term. no.	Term. name	Description
1	G	24 V AC (or DC+)
2	G0	System zero
3	C1	LONWORKS TP/FT-10
4	C2	
.		
9	Fail-safe	
10	Fail-safe	

MAINTENANCE

Keep the unit dry and clean it externally with a dry cloth when needed.

TAC and TAC products are trademarks and/or registered trademarks of TAC AB. All other trademarks belong to their respective owners. Copyright 2002 © TAC AB. All rights reserved.